

**BS-VI**



*Scooty*  
**ZEST** / **110**

**OWNER'S MANUAL**



ALWAYS USE TVS-M GENUINE PARTS

CONTACT(S) FOR SUPPORT	1
UNIQUE FEATURES OF TVS SCOOTY ZEST	5
FOREWORD	10
NOTICE	11
SAFETY INFORMATION	12
RUNNING-IN INFORMATION	13
SAFE RIDING TIPS	14
KNOW YOUR TVS SCOOTY ZEST	18
RIDING YOUR TVS SCOOTY ZEST	35
MAINTENANCE	40
WARRANTY AND SERVICES	64
TECHNICAL SPECIFICATIONS	71
EXPRESS SERVICE	74
EXPERT ON WHEELS	75
PICKUP AND DROP	76
GENERAL INFORMATION	77



**Incase you need any Clarification please contact**

**TVS Motor Company Authorised Main Dealer / Authorised Dealer**

**Or**

**TVS Motor Company's Area Offices (go to subsequent pages for addresses)**

**Or**

**Toll Free Number : 1800-258-7111**

**Email : [customercare@tvsmotor.com](mailto:customercare@tvsmotor.com)**

**Disclaimer :** TVS Motor Company or any of its officials / Authorized Main dealer / Authorized Dealer do not ask customers for bank / card / wallet details / authentication. In case you face any such claim, please report to the relevant local authorities immediately.

**CONTACT AT OUR AREA OFFICES****TAMILNADU-1, 3 & 4****1. TVS Motor Company Limited**

V Floor, Gee Gee Universal,  
No. 2, MC Nichols Road,  
Chetpet, Chennai - 600 031.  
Phone : 044-28361651/28361654  
Email : AO.Chennai@tvs motor.com  
AO.Madurai@tvs motor.com

**TAMILNADU-2****2. TVS Motor Company Limited**

No. 10, 2nd floor,  
Shree Shanmugapriya Towers,  
Kannuswamy Street,  
Behind Hotel Annapoorna,  
R S Puram, Coimbatore - 641 002.  
Phone : 0422-4350060/2541035  
Email : AO.Coimbatore@tvs motor.com

**KERALA****3. TVS Motor Company Limited**

Ambady Towers, Second Floor,  
Door No. 27/631, A6,  
Edappally-Pookkattupady Road,  
Edappally PO., Cochin - 682 024.  
Phone : 0484-2544578/2556938  
Email : AO.Cochin@tvs motor.com

**KARNATAKA-1, 2 & GOA****4. TVS Motor Company Limited**

No. 600, Anand Surya, 2nd Floor,  
15th Cross, 6th Phase, JP Nagar,  
Opp. BMTC Bus Stop,  
Bangalore - 560 078.  
Phone : 080-26653433  
Email : AO.Bangalore@tvs motor.com  
AO.Hubli@tvs motor.com

**ANDHRAPRADESH -1 & 2****5. TVS Motor Company Limited**

Rukumani Towers, First Floor,  
No. 3-11-30, Plot No. 11,  
Paigha Colony, Behind Anand Theater,  
Secunderabad - 500 003.  
Phone : 040-27840590/27844419  
Email : AO.Hyderabad@tvs motor.com  
AO.Vijayawada@tvs motor.com

**MAHARASHTRA-1 & 2****6. TVS Motor Company Limited**

No. 401, 4th Floor, The Chambers,  
Plot No. 4/12/3, Near Ganapati Chowk,  
Viman Nagar, Pune - 411 014.  
Phone : 020-26632111/26632110  
Email : Service.pune@tvs motor.com

**MAHARASHTRA-3 & CHATTISGARH****7. TVS Motor Company Limited**

No. 502B, 6th Floor, B Wing,  
Shriram Shyam Towers,  
Near LIC Square, Sardar,  
Nagpur - 440 001.  
Phone : 0712-2569932  
Email : Service.Nagpur@tvs motor.com  
AO.Rajpur@tvs motor.com

**GUJARATH****8. TVS Motor Company Limited**

109, Ayna Complex,  
Opp. Suvarna Villa Bungalows,  
100 ft Thaltej Hebbatpur Road,  
Off : S.G. Highway, Thaltej,  
Ahmedabad - 380 054.  
Phone : 079-65443748  
Email : AO.Ahmedabad@tvs motor.com

**MADHYA PRADESH-1 & 2****9. TVS Motor Company Limited**

No. 211-212, 2nd Floor,  
Chinar Incube Business Centre,  
Chinar Fortune City,  
Near Brindhavan Dhaba,  
Hosangabad Road,  
Bhopal - 462 026.  
Phone : 0755-2499406/2499306  
Email : AO.Bhopal@tvs motor.com  
AO.Indore@tvs motor.com

**RAJASTHAN-1 & 2****10. TVS Motor Company Limited**

Plot No. 17-18,  
2nd Floor of National Motors Building,  
Jhotwara Industrial Area,  
Jaipur - 302 012.  
Phone : 0141-5150901/5150902  
Email : AO.Jaipur@tvs motor.com  
AO.Udaipur@tvs motor.com

**DELHI & HARYANA****11. TVS Motor Company Limited**

D-3 & D-4, 2nd Floor,  
Sector - 10, Noida,  
Uttar Pradesh - 201 301.  
Phone : 011-29834640/29834773  
Email : AO.Delhi@tvs motor.com  
AO.Haryana@tvs motor.com

**PUNJAB & CHANDIGARH****12. TVS Motor Company Limited**

4th Floor, Royal Business Park,  
Chandigarh Ambala Highway,  
Zirkapur - 140 603.  
Phone : 01762-464777/465777  
Email : AO.Chandigarh@tvs motor.com

**UTTAR PRADESH WEST****13. TVS Motor Company Limited**

D-3 & D-4, 2nd Floor,  
Sector - 10, Noida,  
Uttar Pradesh - 201 301.  
Phone : 011-29834640/29834773  
Email : AO.Upw@tvs motor.com

**UTTAR PRADESH CENTRAL & EAST****14. TVS Motor Company Limited**

1st Floor, Cyber Tower, TC-34/N-2,  
Vibhuti Khand, Gomti Nagar,  
Lucknow - 226 010.  
Phone : 0522-4918300/4918301  
Email : AO.Upe@tvs motor.com  
AO.Upc@tvs motor.com

**WEST BENGAL****15. TVS Motor Company Limited**

Ground Floor & First Floor,  
133 A. S. P. Mukherjee Road,  
Opp. Tollygunge Police Station,  
Kolkatta - 700 026.  
Phone : 033-24617096/24617092  
Email : AO.Kolkatta@tvs motor.com

**BIHAR****16. TVS Motor Company Limited**

N-Plaza, Jamal Road,  
P.S. Kotwali,  
Patna - 800 001.  
Phone : 0612-2200068/2200069  
Email : AO.BNJ@tvs motor.com

## **ORISSA & JHARKHAND**

### **17. TVS Motor Company Limited**

No. 303, 3rd Floor,  
Creative Plaza, Rasulgarh,  
Bhubaneshwar - 751 010.  
Phone : 0674-2580019  
Email : AO.Bhubaneshwar@tvsmotor.  
com

## **NORTH EAST STATES**

### **18. TVS Motor Company Limited**

147, Udayan, Ganesh Guri,  
Opp. Punjab National Bank,  
R G B. Road, Guwahati - 781 005.  
Phone : 0361-2202030/2202031  
Email : AO.Guwahati@tvsmotor.com

## UNIQUE FEATURES OF TVS SCOOTY ZEST

### ZEST for POWER

#### Next-Gen 110cc CVTi ENGINE

Your scooter is powered by a Next Gen 110cc CVTi ECO Tuned Fuel Injection technology engine.

Your scooter also has Best in class Power-to-weight ratio with Best in class pickup. It makes your scooter smooth and zip through traffic with ease.

### ZEST for STYLE

Your scooter comes in vibrant colour ensuring you always arrive in style.

### BACK-LIT SPEEDOMETER

Your scooter comes with a stylish back-lit speedometer,



### LEAF-SHAPED MIRROR

The leaf-shaped mirrors enhance the style quotient of your scooter. Style comes with performance as these mirrors can be adjusted easily. You can adjust them up-down, forward-backward and rotate as well, for enhanced visibility & safety.



### LED TAIL LAMP CUM BRAKE LAMP

Your scooter has an LED tail lamp that makes it look stylish at night also.



### TWILIGHT LAMP

Your scooter has twin twilight lamps located on the front panel, for you to choose your stylish lighting on the go.



### NEW TEXTURED FLOOR BOARD

Your scooter comes with a stylish textured floor board.

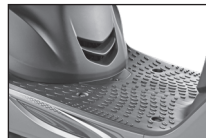

**TVS** 



### **STAINLESS STEEL MUFFLER GUARD**

The stainless steel muffler guard on your scooter not only protects you from hot muffler but also adds a dash of style to its sporty looks.



### **SPORTY DOUBLE STITCHED SEAT**



### **PAINTED SWITCH PANEL**



### **ZEST for COMFORT RIGHT ERGONOMICS**

Your Scooter comes with right weight of 103 kgs for easy handling and zippier rides. Also, Right Seat height of 760 mm on your scooter ensures good ground reachability while adding safety.



### **FRONT TELESCOPIC SHOCK ABSORBERS & REAR DOUBLE RATED HYDRAULIC MONO- SHOCK SPRING SUSPENSION**

Your scooter comes with superior suspension that enhances ride comfort even when you ride over potholes, bumps or bad roads.

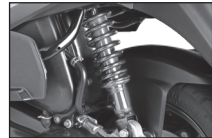

### **WIDE COMFORTABLE SEAT**

A wide comfortable seat ensures that your posture while riding is relaxed and your pillion is seated comfortably too.

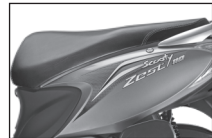

### **ABS BODY**

The ABS body of your scooter is tough and ensures comfort while riding.



### **ZEST for CONVENIENCE LARGEST UNDER-SEAT STORAGE (UTILITY BOX)**

Your scooter has the largest 19 litre under-seat storage space to carry your bags, books, and belongings.



### **TUBELESS TYRE**

Your scooter has tubeless tyres for enhanced convenience. You can run the vehicle for a few more kms even after the tyre is punctured.



### **EaZy® CENTRE STAND**

The patented EaZy® Centre Stand of your scooter reduces the effort required to place the scooter on stand.



### **SYNCHRONIZED BRAKING TECHNOLOGY (SBT)**

Synchronized braking technology reduces the stopping distance, While keeping the stability intact.



### **PARKING BRAKE (REAR BRAKE LOCK)**

The parking brake is another unique safety feature which protects your scooter from falling when it is parked on a slope.



### **MFR HEADLAMP**

Your scooter has a “Multi Focal Reflector” – the bright headlamp with a ‘Halogen bulb’ for better visibility in the dark.

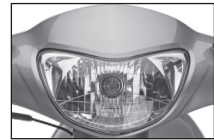

### **RETRACTABLE BAG HOOK**

Your scooter has a retractable bag hook to carry light luggage, like carry bags weighing up to 3 kgs. The hook is located below the handle bar.



### **UNDER-SEAT LUGGAGE HOOK**

For more convenience, another luggage hook is located just under the seat of your scooter.



### HELMET HOOK

Your scooter has one helmet hook under the seat assembly to conveniently place the helmet.

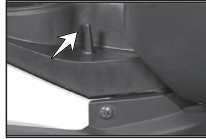

### EASY KICKSTART

The kick lever in your scooter is designed such that the vehicle can be kick-started while you're seated on the vehicle.



### HUGGER FENDER

The hugger fender in your scooter keeps the engine protected & helps to save the pillion rider from mud splashes.



### SMART PHONE CHARGER

Your scooter has a Smart phone charger enable to charge your mobile phone when you are traveling. The utility box light which lights up the utility box whenever the seat is open.



### LED DAY TIME RUNNING LAMP (DRL)

DRL increase the conspicuity of the vehicle during daylight condition "Drive with safety and style." Refer page no. 15 for details



### ZEST for MILEAGE BEST IN CLASS MILEAGE

Your scooter is not only packed with features but also it is easy on your pocket. Its best-in-class mileage ensures you spend lesser on fuel and save more pocket money.

## **ECONOMETER®**

Your speedometer has an **ECONOMETER®** which indicates whether you are riding in Economy Mode. This is a unique feature of your scooter which enables to manage your scooter fuel efficiently.



## **ACCESSORIES FOR YOUR VEHICLE**

### **OPEN FRONT GLOVE BOX\***

An open front glove box is supplied as an accessory for your scooter. It is specially designed to accommodate a 1 litre bottle.



### **FOLDABLE PILLION SIDE FOOT REST\***

The foldable pillion side foot rest is supplied as an accessory for your scooter.



*\* Accessory will be charged extra*

Dear TVS Scooty Zest Owner,

Congratulations and welcome to the world of fun and exciting rides with your **TVS Scooty Zest**.

You've made a smart decision, choosing to ride ahead on the brand new **TVS Scooty Zest**. You'll find that it meets all your needs by striking the perfect balance between power, style, comfort, convenience and mileage.

The stylish new **TVS Scooty Zest** is crafted especially for you. Its 110cc CVTi engine gives you awesome pick-up and zippy rides.

The **TVS Scooty Zest** is also easy to ride – with the right height and the right weight; it offers you the perfect balance of speed and stability, so it's easy to handle on busy roads. With the least turning radius, it is easy to manoeuvre as well.

The benefits of **TVS Scooty Zest** don't end there. With its largest under-seat storage of 19 litres, it gives you the all the space to carry your world with you.

This manual explains in detail, the many features, benefits and operations of your **TVS Scooty Zest**. Do read through your manual carefully, it will help you get the best out of your vehicle, and keep it going strong for years to come. To ensure reliable performance, we urge you to get your **TVS Scooty Zest** serviced only at TVS Motor Company Authorised Main Dealers / Authorised Dealers at regular intervals as specified by your service provider.

We wish you zippy, comfortable, safe and exciting trips for years to come! Get ready to zip ahead with Zest!

**TVS MOTOR COMPANY LIMITED**

All information, illustrations, photographs and specifications contained in this owner's manual are based on the latest product information available at the time of this publication. TVS Motor Company Limited may, however, incorporate modifications or improvements on its vehicles at any time without notice, and therefore, in such events it is possible that the relevant part of the owner's manual does not apply to your vehicle.

Prior permission of TVS Motor Company Limited is required for quoting, copying or reproducing any part of this owner's manual.

**i Note**

*Accessories shown in the picture may not be part of the standard equipment.*

***Your scooter is provided with a day time running lamp (DRL). The DRL glows automatically once the ignition is turned 'ON' and continues to glow till the head lamp is switched 'ON'.***

***Since your vehicle is fitted with side stand cut-off system ensure to retract the side stand before starting the vehicle.***

Operating this vehicle safely is an important responsibility of the rider. To help you make decisions on safety, we have provided necessary operating procedure and other information in this manual. This information alerts you on potential hazards that could hurt you or others. Since it is not possible to warn you about all the hazards associated with operating or maintaining the vehicle, you must use your own judgement.

You will find important safety information in following form in this manual. These words carry the following connotations:

 **Warning**

*Disregarding this message might result in injury to the rider or deadly accidents.*

 **Caution**

*This message indicates special procedures or precautions to be followed to avoid damage to the vehicle.*

 **Note**

*This message provides further clarification for clear understanding of any particular information.*

The first 1000 km is a crucial part for the life of your scooter. Proper running-in operation during this period helps in ensuring a **maximum life** and **smooth performance** of your scooter.

The reliability and performance of your scooter depends on the special care and restraint exercised during the running-in period. It is especially important that you avoid operating the engine in high speed (RPM), which could expose the engine parts to excessive stress. Maximum recommended speed during the running-in is:

**Maximum 50 kmph speed upto 1000 km** (vary the engine speed for better mating of parts).

**The first free service at 500 ~ 750 km is most important.** During running-in period all the engine components and other parts will have set in. All adjustments to be restored, all fasteners to be tightened. **Engine and transmission oil to be replaced.** Timely performance of the first free service will ensure optimum service life and performance from the engine.



### Caution

*Replacing the engine and transmission oil during first free service is most important for better life of engine. Always use TVS TRU4 SKUUTA oil (SAE10W30 API-SL, JASO MB) for better performance and life.*



### SAFE RIDING RECOMMENDATIONS

Any two wheeler riding requires some precautions to be taken to ensure the safety of the rider, pillion and other road users. These precautions are:

#### **Familiarise yourself with new TVS Scooty Zest**

Riding skill and your mechanical knowledge form the foundation of safe riding practices. We suggest you to practice riding TVS Scooty Zest in a low-traffic condition until you are thoroughly familiar with your vehicle and its controls. Remember practice makes you perfect.

#### **Riding apparel**

Loose, fancy clothing can be uncomfortable and unsafe when riding a two-wheeler. Choose good quality two wheeler riding apparel.

#### **Know your limits**

Ride within the boundaries of your own skill at all times. Knowing these limits and staying within the limits will help you avoid accidents.

#### **Warning**

*Two wheeler safety starts with wearing a good quality helmet. One of the most serious injuries that can happen is a head injury. Always wear an ISI approved helmet that should fit your head comfortably and securely. You should also have good quality goggles to protect your eyes and help your vision.*

*To prevent or minimize accident, never consume alcohol or drugs before or during the operation of your vehicle. Even minimal consumption of these will affect the rider's ability to control the vehicle.*

## Posture

Proper vehicle riding starts with proper posture.

1. Keep your elbows relaxed and flexible.
2. Sit and adjust yourself on seat so that arms and shoulders are relaxed
3. Look widely instead of gazing at one point.

## Warning

**One-hand riding is dangerous.** Keep both hands firmly on the handle bar and both feet securely on the floor board. Under no circumstances should both the hands be removed from the handle bar, as it is very dangerous.

**Avoid use of mobile phones while riding as it could lead to fatal accident.**

*Slow down to a safe speed before negotiating a corner. If this is the first time that you are riding a vehicle of this type, we suggest that you practice on a safe, open area to thoroughly familiarise with the operation of the vehicle.*

## Cornering

When cornering, centrifugal force works in a direction perpendicular to the direction in which the vehicle is moving. Centrifugal force increases in proportion with speed and radius of the corner.

During cornering, reduce speed so as to lessen the effects of centrifugal force. By all means, avoid abrupt application of brake or sudden steering.

## Braking

For safe riding, it is very important to master the braking techniques.

1. Close / release the throttle.
2. Hold the vehicle upright as you apply the brake.
3. Progressive application of brake is safer.
4. **Apply both the brakes. 'SBT' provides additional braking even when 'Only Rear brake' is applied, But applying 'Both the brakes' helps you to use the full potential of the brakes.**
5. Riding down hills, while cornering and wet roads close throttle and come to a slower speed to avoid the loss of control over the vehicle due to skidding.

### Causes for poor braking

1. If the brake shoes or drum are worn out or if there is water or oil on them, sufficient friction does not develop and brakes do not work well.
2. Even when the brake works normally, if the road surface is wet or the tyre surface is worn-out, tyres do not take a firm hold on the surface, increasing the stopping distance.
3. Approximately 60% braking effect is from front brake. **Non-usage of front brake causes poor braking.**

### Warning

*As the vehicle speed increases, the stopping distance also increases progressively. Be sure that, you have sufficient distance between you and the vehicle or obstruction ahead of you.*

*Using only the front or rear brake is dangerous and can cause skidding and loss of control. **Apply both the brakes together and with great care on a wet road or other slippery surfaces.** Any abrupt braking on slippery or irregular roads can cause loss of rider control.*

### ACCESSORY INSTALLATION AND SAFETY TIPS

Use extreme caution while selecting and installing the accessories for your scooter.

The addition of **unsuitable accessories can lead to unsafe operating conditions.** Your friendly Dealer will assist you in selecting quality accessories and installing them correctly.

While selecting the accessories, make sure the accessories **should not obstruct lighting, steering, suspension level and ground clearance.**

**Additional electrical equipments is not acceptable as it will void warranty terms of the vehicle.**

## EMISSION CONTROL

All the TVS vehicles are tested in the factory for optimum fuel efficiency and CO levels. If the vehicle needs any adjustments, please consult nearest TVS Motor Company Authorised Main Dealer or Authorised Dealer.

While adequate care is exercised at the factory to ensure that the emissions are within the limits, it is essential for the owner to always maintain the scooter in good condition by getting it periodically checked and serviced by TVS Motor Company Authorised Main Dealer / Authorised Dealer so that the emission and fuel consumption levels are maintained as per norms.

### **Crankcase emission control system**

The engine of new TVS Scooty Zest is equipped with a closed crankcase system to prevent discharging crankcase emissions into the atmosphere. Blow-by gas is returned to the combustion chamber through the air cleaner and the fuel system.

### **Evaporative Emission Control System**

TVS Scooty Zest is equipped with an evaporative emission control system which consists of a canister and associated piping. This system prevents the escape of fuel vapors from the fuel tank.

## **Warning**

*If there is any abnormal jerk, startability issue are felt in the vehicle or noise due to sudden escape of gas during opening of fuel tank cap, immediately report to the TVS Motor Company Authorised Main Dealer / Authorised Dealer.*

## **Note**

***Your vehicle is tested and certified for emission which meets BS VI emission norms and is valid for initial 12 months from the date of purchase. Get your vehicle certified by the Government authorised emission testing station after initial 12 months of usage. And ensure to get the vehicle certified on expiry of the certificate obtained.***

### **VEHICLE IDENTIFICATION NUMBER**

The frame and engine serial numbers are the only means of identifying your vehicle from others of the same model and type. They are also required to assist your Dealer for ordering parts or referring to special information.

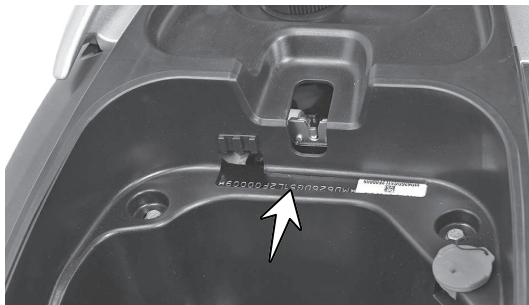

The frame serial number is stamped on the frame, at the rear end below the seat assembly. Open the seat assembly to read the frame number.

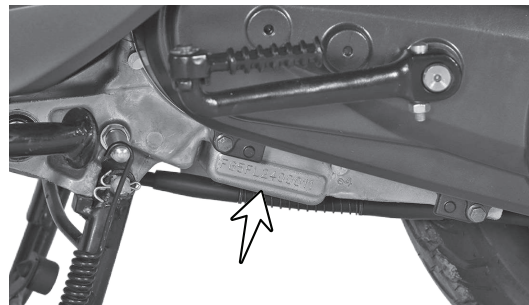

The engine serial number is stamped on the left side of the engine, at the bottom, near center stand mounting. See bottom to read serial number.



## LOCATION OF PARTS - HANDLE BAR

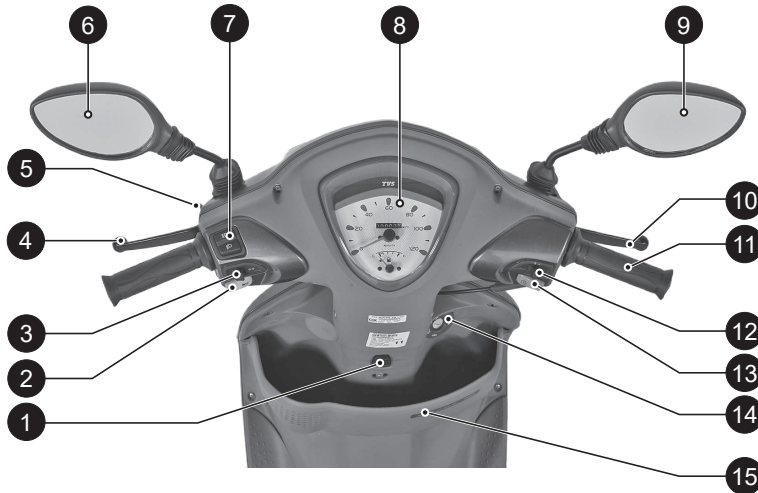

1. Retractable bag hook
2. Horn switch
3. Turn signal lamp switch
4. Rear brake lever
5. Parking brake (rear brake lock)
6. Rear view mirror L
7. High/low beam switch
8. Speedometer assembly
9. Rear view mirror R
10. Front brake lever
11. Throttle grip
12. Lights ON/OFF switch
13. Electric starter switch
14. Ignition cum steering lock
15. Glove box\*

\* Accessory will be charged extra

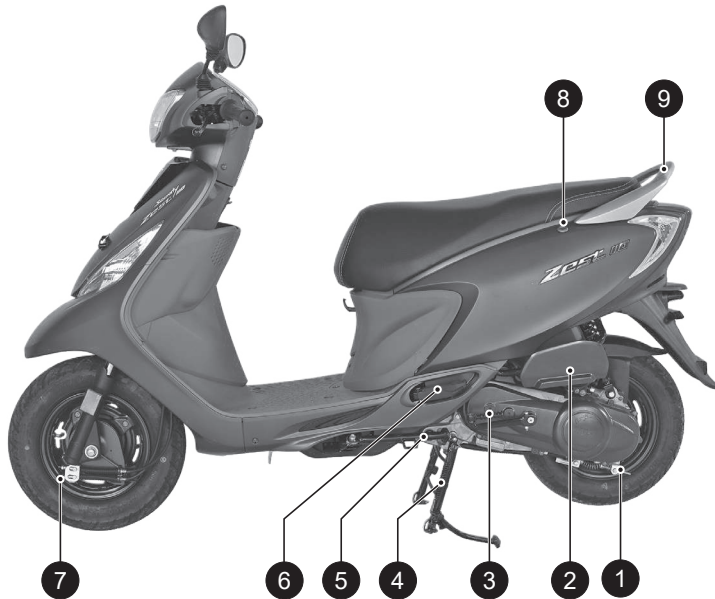
**LOCATION OF PARTS - VEHICLE LEFT SIDE**

1. Rear brake adjusting nut
2. Lady foot rest - foldable\*
3. Kickstarter lever
4. Effortless easy centre stand
5. Side stand\*
6. Pillion foot rest L
7. Front brake adjusting nut
8. Seat lock
9. Pillion handle

\* Accessory will be charged extra

**LOCATION OF PARTS - VEHICLE RIGHT SIDE**

1. Front wheel axle nut
2. Under-seat luggage hook
3. Cover front
4. Pillion foot rest R
5. Gauge oil level
6. Muffler assembly
7. Rear fender
8. Seat assembly
9. Retractable bag hook



## CONTROL KEY

TVS Scooty Zest comes with a pair of identical control keys. These keys are to operate ignition cum steering lock and seat lock.

### IGNITION CUM STEERING LOCK

The ignition cum steering lock enables and disables the electrical circuit and steering lock. The three positions of the lock are described below.

#### 1. 'OFF' position

All the electrical circuits are turned 'OFF' in this position. Engine will not start. Key can be taken out.

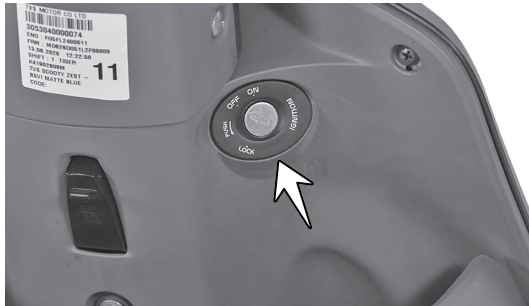

#### 2. 'ON' position

In this position, all the electrical circuits are turned 'ON' and the engine can be started. Key cannot be removed in this position.

#### 3. 'LOCK' position

TVS Scooty Zest steering can be locked in both 'left' and 'right' directions.

To lock the steering, turn the handle bar all the way to the 'left' or 'right'. Push the key IN and turn it to the 'LOCK' position from 'OFF' position. All the electrical circuits are deactivated and the steering is locked. Control key can be removed from the lock.

**Insert the key into the lock and push the key IN and turn it to 'OFF' or 'ON' position to unlock the steering.**

#### Note

*When you switch on the key, the pump priming noise may be heard, which is normal. Avoid frequent SWITCH-OFF & ON of ignition key, to avoid unnecessary run of fuel pump.*

*The day time running lamp (DRL), license plate lamp and tail lamp glow automatically once the ignition key is turned 'ON' without activating any other switches.*

**⚠ Warning**

Never attempt to move the vehicle when the steering is locked, you may lose balance.

**⚠ Caution**

Leaving the ignition cum steering lock in 'ON' position for a prolonged time will drain the battery when the vehicle is not in use. Switch 'OFF' and take the key out when the vehicle is not in use.

Always lock the steering while parking for safety.

**SPEEDOMETER ASSEMBLY****1. Speedometer**

Indicates vehicle speed in kilometers per hour.

**2. Odometer**

Registers and displays the total distance covered by the vehicle in kilometers. The last digit denotes one tenth of a kilometer.

**3. Turn signal indicator lamp left (↶)**

Flashes when the left side turn signal indication is activated.

**4. High beam indicator lamp (⏏)**

Glows when the head lamp high beam is activated.

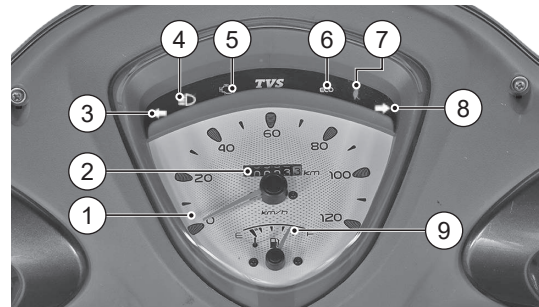

### 5. Malfunction indicator lamp - MIL ( )

MIL is turned ON when the ECU detects a fault in the system.

**If the malfunction indicator lamp '  ' is glowing continually even after the engine is started, immediately contact the nearest TVS Motor Company Authorised Main Dealer / Authorised Dealer.**

### 6. Economy indicator

Eco indicator (green lamp) indicates that the vehicle is running in economy mode which gives better fuel efficiency.

### 7. Side stand indicator

The side stand warning indicator turns 'ON' to alert you whenever the vehicle's side stand is deployed (vehicle parked condition).

### 8. Turn signal indicator lamp right ( )

Flashes when the right side turn signal indication is activated.

### 9. Fuel gauge

Fuel gauge indicates the approximate quantity of fuel available in the fuel tank.

### Note

*Always ride the vehicle in 'Economy Mode' for better fuel efficiency.*

*If the side stand is deployed the vehicle will not start. Retract the side stand to start the vehicle.*

*If there is error in the side stand switch the indication will not glow and the vehicle will not start. In such a condition, please visit the nearest TVS Motor Company Authorized Main Dealer / Authorized Dealer.*

### Caution

***Minimum 1.0 liter of fuel should be maintained in the fuel tank to avoid engine getting 'OFF' / damage to fuel pump which leads to replacement of pump without warranty.***

## HANDLE BAR LEFT SIDE

### 1. Horn switch

Press the switch '🔊' to operate the horn.

### 2. Turn signal lamp switch

Slide the turn signal lamp switch to left '↶' or right side '↷' to operate respective turn signal lamps (LH / RH). Press the switch to turn 'OFF'.

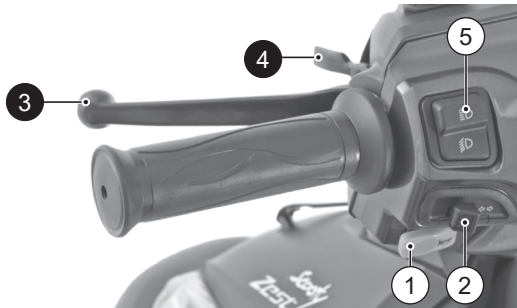

### Warning

Always use the appropriate turn signal lamps when you intend to change lanes or take turns. Be sure to switch it 'OFF' after negotiating the lanes or turns.

### 3. Left hand brake lever (SBT brake lever)

Synchronised Braking Technology (SBT) can be operated by pressing the left hand brake lever gently towards the handle grip.

SBT technology helps to operate both front and rear brakes by distributing the force optimally between the two braking system.

### 4. Parking brake (rear brake lock lever)

Brake lock protects your scooter from rolling-off, when parked on side stand (or) helps you relax while waiting in a long traffic signal (or) a slope.



To activate brake lock, press the brake lever almost half towards the grip and hold, then press the parking brake lever to maximum and release the brake lever slowly. Ensure the brake is locked properly. Pressing the brake lever further releases the brake lock automatically.

### Warning

Since your vehicle is fitted with SBT brake system it is essential to maintain the brake system in good condition. Adjust the brakes system at regular intervals for the proper working of SBT.

Ensure to release the brake lock before riding the vehicle.

## 5. High/low beam switch

With the head lamp 'ON', press switch the towards '  ' to operate head lamp high beam or press it towards '  ' to operate head lamp low beam.

### **Warning**

*Use appropriate head lamp beam 'high / low' as per the traffic and road conditions for your safety and avoid inconvenience to other riders.*

## HANDLE BAR RIGHT SIDE

### 1. Right hand brake lever

Front brake system can be operated by pressing the right hand brake lever gently towards the throttle grip. The brake lamp glows on application of either right hand or left hand brake lever.

### 2. Throttle grip

Engine speed is controlled by the rotation of the throttle grip. Twist it towards you to increase the engine speed and twist it away from you or release it to decrease the engine speed.

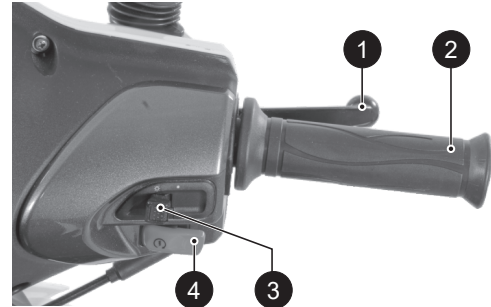

### 3. Lights switch

Light switch has the following two positions. Working of switch at the respective position is as follows:

OFF : All the lamps are turned 'OFF' except DRL lamp and tail lamp when the switch is positioned at '●' even though the engine is running.

ON: Head lamp, position lamps, speedometer back illumination and license plate lamp glows when the switch is positioned at '☀' and engine is running.

### 4. Electric starter switch

Retract the side stand and press the starter switch '⚡' to start the engine electrically along with the application of either front or rear brake.

#### **Caution**

*It is not recommended to add any additional throttle grip (cover).*

### LED DAY TIME RUNNING LAMP (DRL)

TVS Scooty Zest comes with a day time running LED lamp which glows automatically once the ignition is turned ON and continue to glow till the head lamp is switched 'ON'.



#### **Note**

*DRL lamp goes 'OFF' automatically once the head lamp is turned 'ON'.*

## SEAT LOCK

TVS Scooty Zest comes with a lockable seat which need to be opened to access the fuel tank cap, utility box, helmet hook, tool kit and fuse.

Insert the control key into the seat lock and turn it in clockwise direction. Now lift the seat assembly.

To close the seat, gently press the seat in its position and ensure the locking of seat by hearing a 'click' sound and take out the key.



# The fuel tank is not a measuring instrument and the capacity of the fuel tank may slightly vary from the indicated capacity.

## FUEL TANK# CAP

Fuel tank is located at the rear end of the vehicle below the seat. Open the seat as explained earlier to access the fuel tank cap. Remove the fuel tank cap by rotating it in anti-clockwise direction and fill the fuel as recommended. Re-fix the cap and close the seat.



### **Warning**

Never refill fuel near open flame. Do not smoke while refueling. Do not use cell phones while refueling.

 **Caution**

*Ensure that the fuel gun is inserted fully in the tank neck while refueling.*

*Whenever refueling, fill upto the bottom of neck portion (insert level) of the fuel tank. Filling above the neck may result in improper breathing of fuel tank and seepage of fuel.*

*While refueling, avoid spillage of petrol on the tyre. If fuel spills on tyre, the tyre will loose its grip on the road. Ensure to close fuel tank cap without fail to avoid fuel spillage.*

**KICKSTARTER LEVER**

The kickstarter lever is located on the left side of the vehicle. To start the vehicle, keep the ignition in 'ON' condition and apply the rear brake as a safety precaution to prevent the rear wheel rotation.

Keep your foot on the lever extension as shown in the figure. Kick the lever from top and stroke to bottom with rapid motion.





## EFFORTLESS E-Z CENTRE STAND

TVS Scooty Zest is equipped with effortless centre stand. The centre stand (1) has a pivoted flexible spring loaded lever arm (stand extension) (2) to increase the lever ratio, which enables parking on centre stand effortlessly and very conveniently.

To place the vehicle on centre stand, hold the handle bar left grip with left hand. Place your foot firmly on the centre stand extension (2) and press.



Side stand\*



\* Mandatory accessory will be charged extra



### **Caution**

*Never sit on vehicle when it is supported by stands. Always park the vehicle on a flat, firm surface.*

Side stand can be operated by sitting on vehicle with your left foot by pushing it away from the vehicle till it stops.

**⚠ Warning**

***Always retract the side stand to its full up position before starting the vehicle. Else, the vehicle will not get start.***

**TOOL KIT AND FIRST AID KIT**

To assist you in performing certain aspects of periodic maintenance and emergency repairs, a tool kit is supplied along with the vehicle and it is located below the seat base.

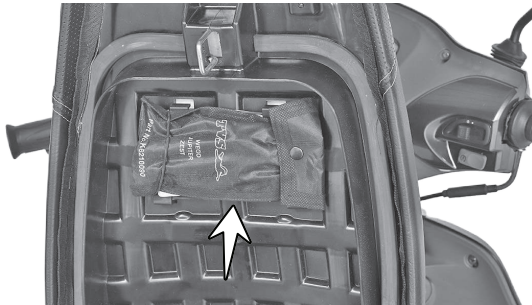

Lift the seat by unlocking the seat lock as explained in page no. 16, to access the tool kit. The tool kit consists one number each of the following. Ensure the contents of tool kit.

1. 16x17 mm box spanner
2. 10x12 mm spanner
3. Combination screw driver bit
4. Screw driver handle
5. Tool bag

**⚠ Caution**

*It is recommended to use the tool kit in case of any emergency only. It is always advisable to take your vehicle to TVS Motor Company Authorised Main Dealer / Authorised Dealer.*

## FRONT GLOVE BOX\*

Open type front glove box is provided in your scooter to store easy and quick access things like notebooks, files, water bottles etc.



### **Caution**

***Recommended not to keep valuable items inside the glove box while leaving the vehicle unattended.***

## UTILITY BOX

Utility box is located below the seat. Lift the seat by unlocking the seat lock as explained in page no. 16 to access the utility box.



### **Warning**

*Utility box can be used to carry a load of 19 litres maximum. Do not carry perishable items inside the utility box. It is not fully sealed. Do not allow / spray water to get inside the utility box.*

\* Accessory will be charged extra

**⚠ Caution**

Take care not to spill petrol or oil into the utility box. Do not keep heat-sensitive items inside as it may get hot on long rides. **Recommended not to keep valuable items inside the utility box while leaving the vehicle unattended.**

**HELMET HOOK**

A helmet hook is provided under the seat, at front right side end of the utility box to secure your helmet. Open the seat assembly as explained in page no. 16 to access the helmet hook. Hook the helmet strap in the helmet hook and close the seat.

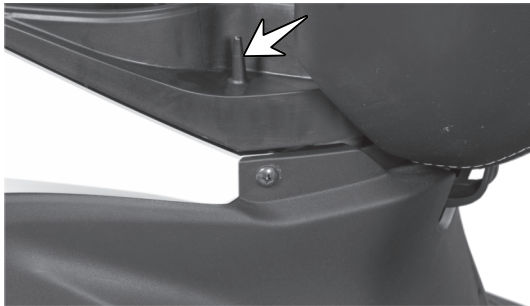

**BAG HOOKS**

There are two bag hooks provided with your scooter to carry light luggage like carry bags weighing upto 3 kg. One hook is located below handle bar on the rear panel which is retractable. Just pull out the hook from the top to hang your luggage. Push back the hook once it is free. The other hook is located on the cover front below front end of the seat assembly.

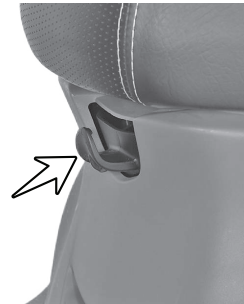

**⚠ Caution**

Care should be taken not to attach the luggage which hangs out of your scooter. Please note that the luggage attached to your scooter should not interfere your feet movement.

## SMART PHONE CHARGER

All new smart phone charging port and utility box light has been provided in the utility box of your vehicle. Please follow the guidelines mentioned below for using it properly:

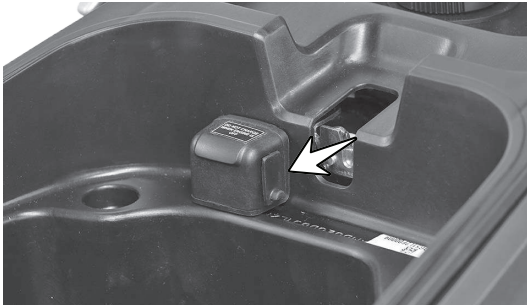

### **Caution**

*The charging time of the mobile may vary, depending on the mobile's battery state of charge. The rubber flap in the unit has been designed to prevent water entry and is not replaceable. No warranty for charger in case of rubber flap cut.*

## DO's

1. Ensure that no water enters into the unit, by closing the USB flap properly.
2. Use the USB, if approved standard USB cable used for charging mobile.
3. The chassis number of the vehicle can be accessed by taking the smart phone charger unit from its mounting. Ensure to refit the charger unit properly.
4. Do not make sure the flap is not damaged while opening / inserting the USB cable.

## DON'TS

1. Do not leave the USB charging flap open / partially closed.
2. Do not attempt to use / charge any other device, other than mobile phones. Only one mobile phone should be charged at a given time.
3. Do not try to force the USB connector in, check whether it is inserted in the appropriate direction, to prevent the damage to the charger.
4. Do not charge your mobile when engine is off.

## PRE RIDE INSPECTION

Check the following items before riding

ITEM	WHAT TO CHECK FOR
Engine oil	Availability of oil upto the level (page No. 36)
Transmission oil	Availability of oil upto the level (page No. 37)
Fuel	Enough fuel for the planned distance of running
Tyres	Correct pressure (page No. 42) Adequate tread depth / No cracks or cuts.
Battery	Proper working of electric starter, horn, fuel gauge, pass by, brake lamp and turn signal lamps. Battery voltage (page No. 32)
Lighting	Proper working of head lamp high / low beam, DRL, high beam indicator, position lamp, speedometer back illumination, tail lamp and license plate lamp.
Steering	Smooth movement / no play or looseness
Throttle	Correct free play of cable / smooth operation
Brakes	Correct front / rear brake lever play (page No. 38)
Wheels	Free rotation of front and rear wheels

### **Caution**

Do not switch 'ON' the ignition without minimum level fuel in the tank. It will cause damage to the pump.

## Starting the engine

Ensure the availability of fuel in the fuel tank. Insert the control key into the ignition cum steering lock and turn it to the 'ON' position. In side stand retracted condition, apply any one of the brake and press the electric starter switch to start electrically or kick start. Press the start button without applying the throttle. As soon as the engine starts, release the start button. The engine will not start if the throttle is opened full.

## Setting the vehicle in motion

1. Twist the throttle grip towards you and simultaneously release the brake lever gently and smoothly. The vehicle will start moving forward.
2. As the vehicle picks up speed, increase the throttle slowly.



### Caution

*Do not keep the engine in idling rpm for long and do not open excessive throttle when the vehicle is parked. It leads to overheating of engine and damage to the internal components.*



### Warning

*Do not raise the throttle rapidly so the vehicle will move forward suddenly and lead to loss of control.*

## Stopping and parking

1. Close the throttle completely and apply both the brakes simultaneously.
2. Turn the ignition 'OFF'.
3. Park the vehicle on a firm, flat surface.
4. Lock the steering and take out the control key.



### Warning

*Reduce speed to a safe limit before turning / cornering. Do not apply brake while turning / cornering.*

## FUEL RECOMMENDATION

Use only BS VI petrol with minimum RON 91.

BS VI petrol containing upto 10% of ethanol by volume can be used.

Higher ethanol content in petrol can

- degrade plastic and rubber components of fuel system and vehicle parts
- cause corrosion damage to metal parts like fuel tank, etc
- result in startability & drivability issues
- decrease fuel economy

Ethanol absorbs water very easily, resulting fuel separation. Extra care shall be taken to prevent moisture entry into fuel tank while filling ethanol blended petrol and water washing of vehicle.

Painted parts (viz. panels, covers) shall not come in contact with ethanol blended fuels.

Manufacturer is not responsible for any warranty issues that results from using ethanol blend in excess of 10% by volume.

In case of any abnormalities observed due to use of ethanol blended fuels, customers are advised to use a different fuel station/brand for standard E10 fuel or contact authorised service centres.

**Caution**

*Never mix oil in petrol in the fuel tank. Always fill fuel from the reputed and reliable fuel stations.*

**CHECKS AND TIPS FOR IMPROVING FUEL ECONOMY****Regular checks**

Carry out the periodic maintenance checks as specified in this manual (page No. 28).

Regular maintenance checks will save fuel and ensure trouble-free, enjoyable and safe riding besides keeping environment clean.

**Spark plug**

A dirty or defective spark plug leads to wastage of fuel due to incomplete combustion. Clean and adjust the spark plug only if necessary. Replace the spark plug every 12000 kms (1 year). Always use recommended spark plug only.

**Air cleaner element**

A dirty air cleaner element restricts airflow and increases fuel consumption. Replace the element every 12000 kms.

Since viscous filter is used in your scooter it is not recommended to clean the filter. Replace the filter incase of any abnormalities.



## Engine oil and Transmission oil

Dirty or less engine oil increases friction between various parts of the engine and reduces the engine life, thereby increases the fuel consumption.

Running with low transmission oil will cause damage to the gears and bearings.

**Regularly inspect the engine oil and the transmission oil for correct level and top-up if necessary. Get it replaced at regular intervals as per the maintenance schedule.**

### Fuel leak

Inspect and arrest fuel leaks if any from tank and fuel lines. Loss of fuel due to leak may drain the fuel tank completely.

### Evaporation

Vehicle parked in the hot sun leads to wastage of fuel through evaporation. Also, lower fuel levels in the tank will have increased evaporation and condensation of moisture inside.

Ensure to close fuel tank cap after every filling. If the fuel tank cap kept open for long time, it leads to safety and fuel loss.

## Tyres

Low tyre pressure has adverse effect on the vehicle. The **drag on the vehicle** increases resulting decreased fuel economy. Further more, handling may be adversely affected.

Inspect the tyre pressure regularly (weekly) and inflate it to the recommended pressure (refer page No. 42). Never use tyres which are worn beyond the permissible limit.

### Wheel freeness

Inspect and ensure the wheel freeness by rotating the wheel at least once in a week to avoid wastage of fuel.

### Avoid unnecessary idling

While waiting for someone or stopping in signals for long time, if the engine is kept running at idle speed, it causes unnecessary wastage of fuel.

### Avoid frequent braking

Anticipate corners and slopes as well as the traffic conditions. **Unnecessary and frequent braking will reduce the fuel economy. Never accelerate and apply brake simultaneously.** It leads clutch shoes wear and wastage of fuel.

**i Note**

*The on-road mileage of TVS Scooty Zest is dependent on several factors like road condition, quality of fuel, riding speed, operation of throttle and brake, tyre inflation, maintenance / timely servicing of vehicle, load etc.. and hence will differ from the mileage given under standard test conditions such as made in recognised institutes.*

## MAINTENANCE SCHEDULE

The maintenance schedule indicates the intervals between periodic services. At the end of each interval, be sure to inspect, check, replace, adjust, lubricate and service as instructed. If the maintenance is not done periodically, it will result in rapid wear and severe damage to the vehicle. If the vehicle is used under high stress conditions such as continuous full throttle operation or is used / operated in dusty area, certain jobs should be performed more often to ensure reliability of the vehicle. Cylinder head, steering components, suspension and wheel components etc., are key items and require very special and careful servicing. TVS Motor Company Limited strongly recommends that the jobs as per the maintenance schedule be performed by your TVS Motor Company Authorised Main Dealer / Authorised Dealer.

Periodic inspections may reveal one or more parts that may need replacement. Whenever replacing parts on TVS Scooty Zest, it is recommended that you use only the **TVS Motor Company Genuine** parts.



### Caution

*Proper running-in and maintenance are mandatory for making certain that your vehicle is reliable and gives optimum performance at all times. Make sure that the periodic maintenance is performed thoroughly in accordance with the instructions given in this owner's manual.*

*In more dusty areas, the air filter element required early inspection than the mentioned kilometers to avoid costly damages to the engine.*



## PERIODIC MAINTENANCE SCHEDULE (months or km whichever occurs earlier)

Item	Service km Period from the date of sale	In free service				After free service		Remarks
		1st 500 - 750 2 months	2nd 2500 - 3000 4 months	3rd 5000 - 6000 8 months	4th 8500 - 9000 12 months	Every 3000 km 4 months	Every 6000 km 8 months	
Engine oil		R	I & T	R	I & T	I & T	R	
Oil filter (strainer)		C	-	C	-	-	C	
Transmission oil		R	I & T	R	I & T	I & T	R	
Spark plug		I	-	-	-	-	-	Inspect, Clean and adjust if required. Replace every 12000 km
Air cleaner element		I	-	-	-	-	-	Replace every 12000 km
Air cleaner oil collection tubes		-	I & DR	I & DR	I & DR	I & DR	-	Drain oil if necessary
CVT filter element <sup>1</sup>		-	-	I & C	-	-	I & C	Replace every 12000 km
Tappet clearance		I	-	I & A	-	-	I & A	Inspect for any noise / starting trouble and adjust if required
Drive belt and CVT rollers		-	-	-	-	-	-	Replace every 24000 km
Cover variator <sup>2</sup>		-	-	I, C & L	-	-	I, C & L	
Clutch shoe		-	-	-	-	-	-	Replace every 24000 km
Hose fuel		-	-	-	-	-	-	Replace every 3 years
Front and rear suspension		I	I	I	I	I	-	Inspect for proper functioning
All control cables <sup>3</sup>		I, A & L	I, A & L	I, A & L	I, A & L	I, A & L	-	

R - Replace; I - Inspect; T - Top up; C - Clean; A - Adjust; DR - Drain; L - Lubricate; TI - Tighten; S - Set

<sup>1</sup> Inspect for damage

<sup>2</sup> Clean the cover with air. Lubricate kick starter with Bechem grease

<sup>3</sup> Inspect for proper operation and adjust play. Lubricate ends using grease

Contd...

Item	Service km	In free service				After free service		Remarks
		1st 500 - 750 2 months	2nd 2500 - 3000 4 months	3rd 5000 - 6000 8 months	4th 8500 - 9000 12 months	Every 3000 km 4 months	Every 6000 km 8 months	
Throttle grip		–	–	L	–	–	L	Lubricate using grease
Steering smooth operation / play		I & A	–	–	–	–	–	C, L & A with fresh grease every 12000 km
Speedo hub drive / cable		–	–	L	–	–	L	Lubricate using grease
Front fork oil		–	–	–	–	–	–	Replace every 24000 km
All fasteners		I & TI	I & TI	I & TI	I & TI	I & TI	–	
All bulbs, horn and switches		I	I	I	I	I	–	Inspect for proper functioning
Head lamp beam		I & A	I & A	I & A	I & A	I & A	–	
Battery electrolyte level		I & T	I & T	I & T	I & T	I & T	–	
Specific gravity & voltage <sup>4</sup>		I	I	I	I	I	–	
Brake effectiveness / play		I & A	I & A	I & A	I & A	I & A	–	Refer page No. 58 & 61 for details
Brake cam		–	–	C & L	–	–	C & L	Lubricate using grease
Wheel freeness		I	I	I	I	I	–	
Front wheel bearing		–	–	–	–	–	–	Lubricate using grease every 12000 km
Tyre pressure at cold condition		I & S	I & S	I & S	I & S	I & S	–	
Malfunction indicator lamp		I	I	I	I	I	–	Check and resolve the errors using diagnostic tool if the lamp is ON even after starting the engine

<sup>4</sup> Recharge if necessary

Contd...

Item	Service km	In free service				After free service		Remarks
		1st 500 - 750 2 months	2nd 2500 - 3000 4 months	3rd 5000 - 6000 8 months	4th 8500 - 9000 12 months	Every 3000 km 4 months	Every 6000 km 8 months	
Evaporative emission control system		I	I	I	I	I	-	Check for intactness of hoses and canister
Fuel tank assembly**		I & C	I & C	I & C	I & C	I & C	-	
Centre / side stand pivot		L	L	L	L	L	-	Lubricate using TRU4 oil
Kick starter pedal pivot		L	L	L	L	L	-	Lubricate using TRU4 oil

R - Replace; I - Inspect; T - Top up; C - Clean; A - Adjust; DR - Drain; L - Lubricate; TI - Tighten; S - Set

\*\* Check for abnormal vehicle jerk / noise while opening the cap / leak. If found any, contact TVS Motor Company Authorised Main Dealer or Authorised Dealer.

## RECOMMENDED LUBRICANTS

APPLICATION	QTY	MANUFACTURER	BRAND
Engine oil	750 ~ 800 ml (during regular service) 800 ml (incase of disassembly)	TVS Motor Company	TVS TRU4 SKUUTA oil (SAE 10W30 API-SL, JASO MB)
Transmission oil	100 ml (during regular service) 120 ml (incase of disassembly)	-do-	-do-
Front fork oil	53 ± 1 ml / leg	IOC	Gabriel Premium front fork fluid
Grease	-	Bharat petroleum IOC Bechem Kluber Lubrication	MP Grease no. 3 Servo Gem no. 3 Bechem premium 3 Kluber Centoplex 2

## SELF - MAINTENANCE PROCEDURES

### BATTERY

Electrolyte level and the condition of battery must be inspected periodically to avoid failure of battery. Battery is located below the seat, at front end and enclosed by the utility box.

To access and inspect the battery, utility box must be removed in the following manner.

1. Open the seat by unlocking the seat lock (refer page No. 16).
2. Remove the mounting bolts of utility box using suitable spanner.

3. Take out the utility box along with the seat while carefully disconnecting the wiring socket of utility box lamp and diagnostic coupler (please note that the seat comes along with utility box since it is mounted on the utility box).

Now, inspect the electrolyte level of the battery. The electrolyte must be between maximum and minimum level. If the electrolyte level is below minimum level, add only distilled water upto the maximum level by removing the filler caps.

Reinstall the filler caps and clean the battery thoroughly, apply petroleum jelly to the terminals of battery to protect it from corrosion.

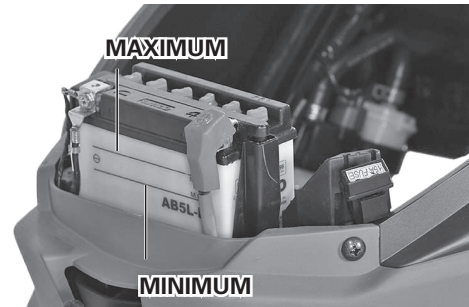
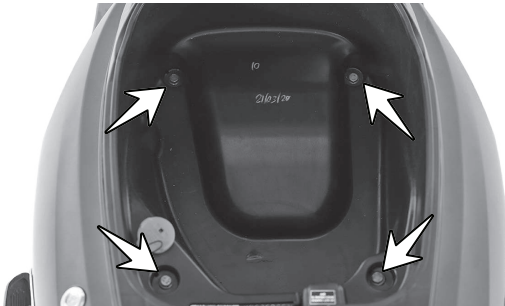



While connecting the terminals, observe the correct polarity. Connect the red wire to the '+' terminal and black wire to the '-' terminal of the battery.

Incase of any abnormality or for removal of battery from the vehicle, contact TVS Motor Company Authorised Main Dealer / Authorised Dealer.



### **Caution**

*Never check the battery charge by shorting the terminals.*

*Always connect the positive terminal first (red wire) and then negative (black wire) to avoid sparking. The inversion of the battery wires can damage the battery and the recharging system.*

### **Recommendations to maintain battery health during prolonged parking conditions**

While your vehicle is parked for prolonged duration, battery continues to discharge and if left unattended can get completely discharged. It is recommended to ride the vehicle for minimum 60 km every week to keep the battery in healthy condition This could be at a stretch in one ride or several rides during the week.

The vehicle speed will vary during the ride but an average speed of minimum 30 kmph will be helpful to ensure proper battery charging. Use kick-starting, if available, to conserve battery charge during such period. This is only a recommendation to maintain battery charge and regular service schedules must be followed to maintain your vehicle in good running condition.

The following is recommendations to users regarding battery maintenance before, during and after long storage of battery:

#### **1. Before Storage**

- a. Store the battery only after fully charging it
- b. Battery fuse to be disconnected and stored safely. This will reduce the sleep mode current and hence enhance storage life of battery.\*

\* To be done by skilled personnel

- c. Alternatively, battery connecting wires (positive and negative wires) can be disconnected and fasteners can be secured with battery terminals.\*

## 2. During Storage

- a. Store it at room temperature or lower.
- b. Store the vehicle in the shade and protected from rain and cover the vehicle to prevent rodents from entering and damaging the wires.

## 3. After Storage

- a. Connect the wires and fuse, if disconnected earlier, with ignition switch in OFF position\*
- b. Start the vehicle by kick starting.

(Above recommendations do not consider storage effects on other systems such as induction and fuel systems and wheels)

### Periodic Maintenance of Batteries:

- Keep top of battery clean
  - Check cables, clamps, and case for obvious damage or loose connections
  - Clean terminals and connectors as necessary
- Recharge battery if voltage is below 12.4 Volts.

- Valve Regulate Lead Acid (VRLA) / Lead Acid batteries are prone to water damage. Any water entry, through vents or otherwise; will result in irreparable damage to the battery or the vehicle.

### **Warning**

*Battery develop explosive gases. Keep it away from heat sources. If charging is required the battery must be charged in well ventilated area.*

*Unusable battery must be disposed in environment friendly manner. Do not discard it with household trash. Handover the battery to the battery dealers or to a recycle center that accept used battery.*

### **Caution**

*Never operate the vehicle with discharged battery as it may damage electrical components.*

*Do not push start the vehicle, use a good battery to start the vehicle.*

\* To be done by skilled personnel

## FUSE

Non-working of electrical systems may be due to safety fuse failure. Short circuit or overload in the electrical system are the main causes for the fuse failure.

A fuse case having 10 Amps fuse (blade type) is fitted on the front left side of the utility box below seat. Follow the procedure for the removal, inspection and replacement of the fuse.

1. Open the seat as explained in page No. 16.
2. Take out the fuse case from the utility box.
3. Open the fuse case and pull out the blown fuse.

Good Fuse

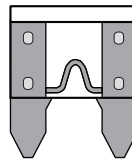

Blown Fuse

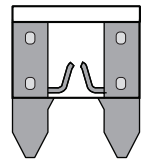

4. Fix a new fuse (extra fuse is provided in the wiring harness itself in a pouch).
5. Turn the ignition switch 'ON' and check for the proper working of battery operated electrical systems.

Incase the fuse blows off again, consult the nearest TVS Motor Company Authorised Main Dealer / Authorised Dealer.

### **Caution**

*Do not use vehicle by shorting the wires without fuse. This may result in overheating of electrical items / wiring and may result in fire of vehicle.*

*Do not use fuse of higher amperage than specified for the safety of electrical system.*

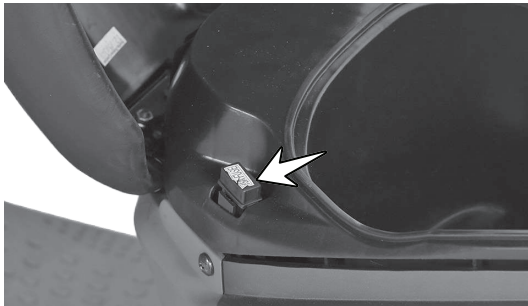

## SPARK PLUG

To access the spark plug, cover front need to be removed. Follow the procedure given below for the removal of cover front and spark plug.

1. Remove the bottom mounting screw (A).
2. Open the seat by unlocking the seat lock (page No. 16) and remove the top mounting screw (B) from both the sides of the cover front.
3. Gently pull out the cover by dislocating its lugs.
4. Clean the dust and mud around the spark plug mounting to avoid falling inside the cylinder.
5. Using spark plug spanner of tool kit, remove the spark plug.

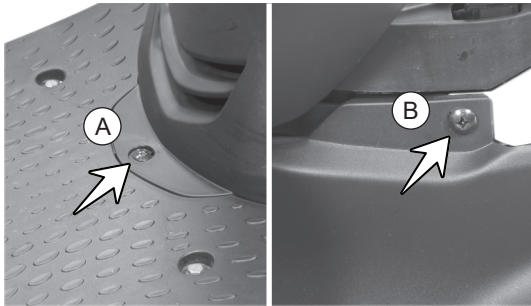

A spark plug with heavy carbon deposits will not produce strong sparks. Hence, only if necessary, clean the carbon deposits from the spark plug with a small wire brush or spark plug cleaning tool.

Inspect the spark plug electrodes (A) and (B) for any corrosion. If found any, replace the spark plug with a new. Inspect the spark plug gap with a wire gauge / feeler gauge. Readjust the spark plug gap to **0.9 ~ 1.0 mm / 1.0 ~ 1.1 mm** if required.

After cleaning and adjusting the gap, reinstall the spark plug and tighten by hand to avoid cross threading. Finally tighten using spark plug spanner.

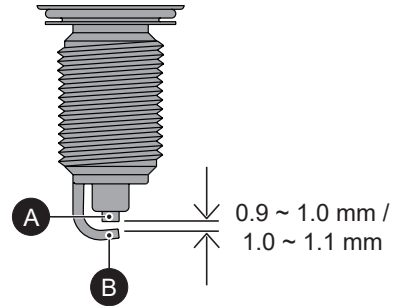

**Caution**

*Always use only recommended make and type of spark plug. Replace the spark plug every 12000 km.*

*Don't remove the spark plug when the engine is hot. Cover the spark plug hole with a cloth when the plug is removed to prevent entry of dust / water.*

*Do not try to adjust the spark plug as it may damage the plug. Replace the plug if the gap is found more.*

*It is advisable to tighten the new spark plug by hand till the end, using plug spanner tighten by 1/4 turn. Then loosen the plug by 1/8 turn and re-tighten using plug spanner.*



## ENGINE OIL LEVEL

Check the engine oil level periodically.

1. Place the vehicle with the centre stand on a flat surface. Wipe-off the surroundings of gauge oil level.
2. Remove the gauge and wipe it clean.
3. Fix the gauge back to its mounting hole. Do not thread in.
4. Take out the gauge and check the oil level. The level should be between minimum and maximum level marks of the gauge (shown in the figure).

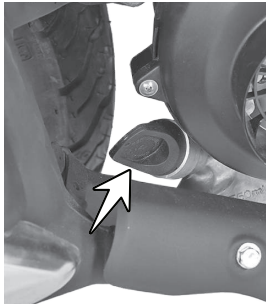

5. If the oil level is less than the minimum level, add TVS TRU4 SKUUTA oil only (SAE 10W30 API-SL, JASO MB) oil upto the maximum level mark.
6. Wipe out the oil traces with a clean cloth to prevent dust accumulation.
7. Assemble back the gauge oil level.



### Caution

*If the vehicle is driven with less engine oil, the engine components will be severely damaged.*

*Check the oil level as per the schedule to avoid costly damage. Do not fill excess oil may cause oil leak. Always use 'TVS TRU4 SKUUTA (SAE 10W30 API-SL, JASO MB)' oil only.*

## TRANSMISSION OIL LEVEL

Check the transmission oil level periodically.

1. Place the vehicle on centre stand on a flat surface. Wipe-off the surroundings of oil level screw.
2. Remove the transmission oil level screw along with a gasket from the rear end of crankcase L.
3. Check for the flow of oil from oil level hole.
4. If the level is less (if there is no oil flow), top-up with TVS TRU4 SKUUTA (SAE 10W30 API-SL, JASO MB) oil till the it just starts to flow out from the oil level hole.
5. Wipe out the oil traces with a clean cloth to prevent dust accumulation.

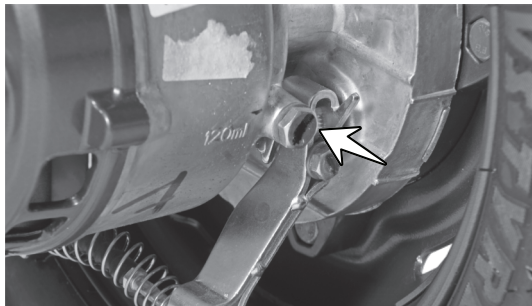

6. Reassemble the oil level bolt with new fiber washer.



### Caution

*If the vehicle is driven with less transmission oil, the transmission components of engine will be severely damaged.*

*Check the oil level as per the schedule to avoid costly damage. Do not fill excess oil may cause oil leak.*

*Always use 'TVS TRU4 SKUUTA (SAE 10W30 API-SL, JASO MB)' oil only.*

## BRAKES

### Front brake

1. Measure the free play of the front brake lever at lever end as shown in the figure.
2. The free play of the brake lever before the engagement of brake should be between 15 ~ 20 mm.
3. Turn the adjuster nut at the top (1) in the slot marked as "I" in clockwise direction for reducing the free play or in anti-clockwise direction for increasing the free play.

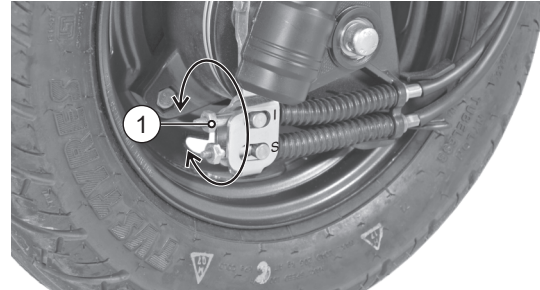
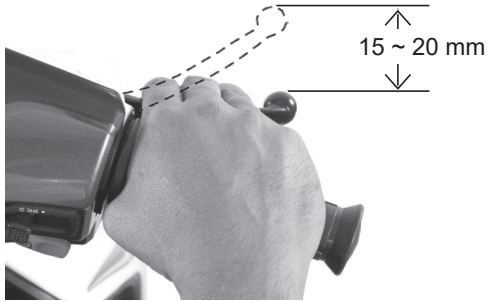

4. After obtaining the necessary free play, inspect for the clearance between the bullet (3) and slot end (4) marked as "S" as shown in the figure.

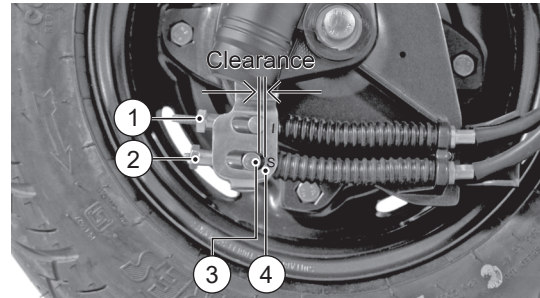



5. If any clearance is found, turn the adjuster nut (2) at the bottom side in the slot marked as "S" in clockwise direction until there is no clearance between the bullet bottom (3) and the slot bottom (4).

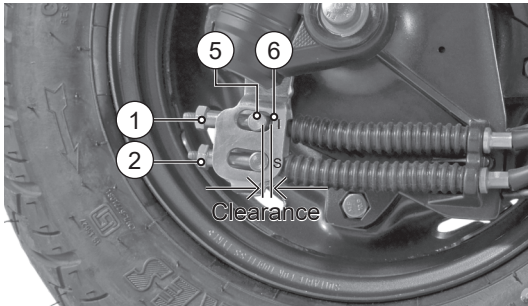

6. After adjusting the bottom adjuster nut, if any clearance is observed between the bullet top (5) and the slot top (6) marked as "I" as shown, then turn the adjuster nut (2) in anti-clockwise until there is no clearance.
7. Once again check and confirm the brake play at the lever end.

### **Warning**

*Since the vehicle is fitted with Synchronised Braking System (SBS) adjust the brakes with additional care. If not it may result in brakes not working properly. Please contact TVS Motor Company Authorised Main Dealer or Authorised Dealer for any further assistance.*

### Brake shoe wear indicator - Front

When the brake is applied, wear limit index mark (1) on the front brake cam should be within the wear limit indicator (2) on the front brake panel.

Incase the wear limit index mark (1) is going beyond wear limit indicator (2), index the lever to next slot with the help of the Dealer to extend the shoe life.

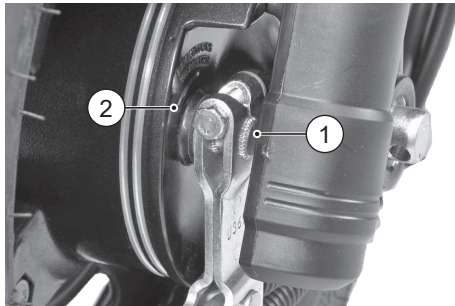

### Caution

Replace the brake shoes as a set, if the wear limit indicator shows beyond the wear limit even after indexing the lever.

### Rear brake

1. Measure the free play of the rear brake lever at the lever end as shown in the figure.
2. The free play of the brake lever before the engagement of brake should be between 10 ~ 15 mm.

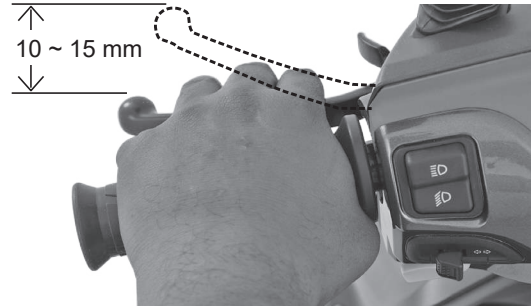

### Note

**Please remember that the rear brake lever free play adjustment to be done only after adjusting the front brake lever play.**

3. If the measured free play is more than the limit, adjust the nut provided at rear wheel end to obtain correct play.
4. Turn the adjuster nut in clockwise direction for reducing free play or in anti-clockwise direction for increasing free play.



**⚠ Warning**

Check front brake (drum brake type) and rear brake play periodically. However the brake play needs to be adjusted more frequently depending upon the usage.

**Brake shoe wear indicator - Rear brake**

When brake is applied, the wear limit indication pointer (1) on the rear brake cam lever should be within the wear limit indicator (2) on the crankcase LH.

In case the wear limit indication pointer (1) is going beyond wear limit indicator (2), index the lever to next slot with the help of Dealers to extend shoe life.

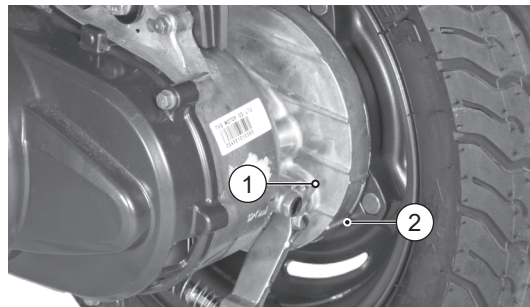

**⚠ Caution**

Replace the brake shoes as a set, if the wear limit indicator shows beyond the wear limit even after indexing the lever.

## TYRES

### Tyre pressure

Check the tyre pressure atleast once in a week if not more frequently. Insufficient air pressure in the tyres not only hasten tyre wear, but also seriously affects the stability of the vehicle.

Under inflated tyres make smooth cornering difficult and over inflated tyres decrease the tyre contact with the ground which can lead to skidding and loss of control. Be sure that the tyre pressure is within the specified limits at all times.

Tyre pressure in cold condition:

	<b>Solo</b>	<b>Dual</b>
Front	1.69 kg/cm <sup>2</sup> (24 PSI)	1.69 kg/cm <sup>2</sup> (24 PSI)
Rear	1.97 kg/cm <sup>2</sup> (28 PSI)	2.25 kg/cm <sup>2</sup> (32 PSI)

### Tyre tread condition

Operating the vehicle with excessively worn tyres will decrease riding stability and can lead to loss of control. It is recommended to replace the tyre when the tyre wears off to the tyre wear indicator level (indicated by TWI (A) on the tyre).



### Tyre rotation direction

While reassembling the tyres after removing from the wheel rim or while assembling a new tyre ensure that the arrow mark (B) provided on the tyre facing the direction of wheel rotation.

### Tyre puncture

Your scooter is fitted with a tubeless tyre on both the wheel. In case of any puncture / tyre damage, it is advised to visit the nearest tyre manufacturer Dealer or the tyre repair shops who knows the repairing method of tubeless tyre. It is not necessary to remove the tyre from wheel rim always to attend a puncture.

Even though, if there is need of tyre removal, it is strongly recommended to use a tyre removal / fitment machine. If at all, tyre levers needs to be used, the levers should be free from sharp edges. Care should be taken not to damage the tyres and rims.

 **Warning**

*The tyre inflation pressure in cold condition and the tyre tread condition are extremely important for the performance and safety of the rider. Check the tyres frequently for inflation pressure as well as the wear pattern on it. Use of a tyre other than the standard may cause instability.*

 **Caution**

*The side walls of the tubeless tyre which in contact with the wheel rim are only seals the air inside the wheel assembly. Hence care should be taken not to damage the side walls of the tyres during removal / reassembly.*

## Tyre Maintenance Tips

### Inflation Pressure Check - Condition

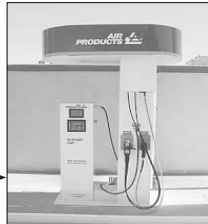

Within  
1 km

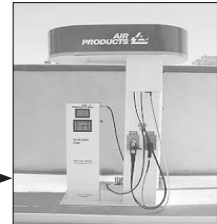

Within  
5 km

### **i** Note

*If vehicle is in hold condition for long time*

- *Need movement of vehicle to avoid particular spot of tyre not to touch the ground for more than week time.*
- *Inflation pressure should check on cold condition maximum travel time should not exceed more than 1 km.*
- *Weekly basis inflation pressure check helps to improve 10% of tread life & fuel efficiency.*

## FRONT WHEEL REMOVAL

1. Remove the axle nut (1) along with a washer. Take out the cover fork tube RH .
2. Pull out the axle (2) along with punched washer and take out the cover fork tube LH.
3. Take out the spacer from the right side of the wheel. Dislocate the hub drive from wheel hub.
4. Place a support below the foot board to prevent vehicle from falling and lift the vehicle up.
5. Dislocate the wheel assembly along with brake panel from front fork. Separate the brake panel from the wheel and take out the wheel.
6. Reverse the procedure for reassembling, while ensuring the proper seating of brake panel slot in the fork leg L lug (LH side) and hub drive lugs in the slots of wheel hub (RH side).

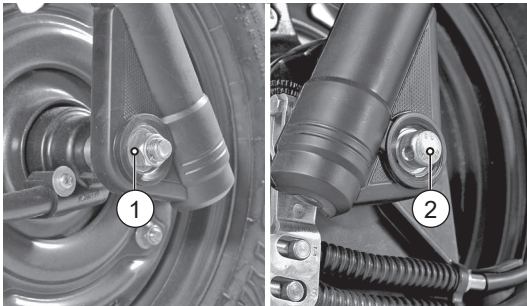

## REAR WHEEL REMOVAL

1. Place the vehicle on the centre stand.
2. Hold the rear brake firmly and remove the wheel mounting nut (A) along with a washer.
3. Slightly tilt the vehicle and take out the wheel from the rear axle.
4. Reassemble the wheel in the reverse order of removal. Hold the rear brake firmly while re-tightening the mounting nut for easy locking of wheel.

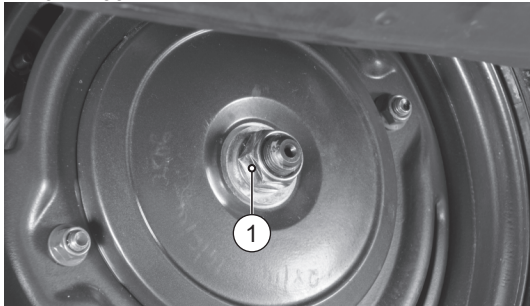

### **Caution**

Always make sure, whenever the wheel is removed, the axle nuts are tightened properly to the specified torque.

## STORAGE PROCEDURES

For storage of your scooter for longer period of over a month and above, we recommend to carry out the following steps:

1. Clean the vehicle thoroughly. Park the vehicle on centre stand.
2. Warm up the engine. Drain engine oil and transmission oil. Store the oil, if new, in a dust free container.
3. Empty the fuel tank.
4. Remove the spark plug and feed in several drops of engine oil through spark plug hole. Crank the engine few times and reinstall the spark plug.

### **Caution**

*Do not park the vehicle on a slope or soft ground or else it may fall down.*

*The exhaust system becomes hot after a run. Park the vehicle in a place where pedestrians or children are not likely to touch the vehicle.*

*During storage, the battery must be recharged at recommended charger if stored more than a month.*



5. Remove the battery, store it away from direct sunlight and freezing temperatures.
6. Place a suitable support at the bottom of the foot board so that both the tyres are off the ground. This will ensure better tyre life.
7. Cover up the vehicle completely with a clean tarpaulin or any other suitable cover. Store the vehicle inside a garage or similar area to avoid damage due to dust and rain. Make sure that the storage area is well ventilated and free from any source of flame or spark.
5. Lubricate the parts as instructed in periodic maintenance schedule.
6. Fill up fresh petrol in the fuel tank.
7. Check and inflate the tyres to the specified tyre pressure.
8. Check and correct the points given in page No. 23.
9. Turn the ignition switch to 'ON' position. Retract the side stand if the vehicle is parked on side stand. Start the engine and let it idle for few minutes and ride out.

#### **TAKING THE VEHICLE OUT OF STORAGE FOR REGULAR USE**

1. Take the vehicle out of garage and clean it thoroughly.
2. Remount the battery after bench charging if required.
3. Fill the engine oil (TVS TRU4 SKUUTA - SAE 10W30 API-SL, JASO MB oil) and check the oil level using gauge oil level.
4. Fill the transmission oil (TVS TRU4 SKUUTA - SAE10W30 API-SL, JASO MB oil) and check the oil level at the oil level inspection screw.



#### **Caution**

*Avoid using alkaline solution like detergent soaps for washing. This may damage head lamp and other lamp assemblies.*

## RECOMMENDED TIPS WHEN TAKING A LONG TRIP OF MORE THAN 500 KM:

- A) Please keep the following items for use in case of emergency:
1. Tool kit complete.
  2. Recommended spark plug one number.
  3. Head lamp and turn signal lamp bulb each one.
  4. Throttle, front and rear brake cable each one.
  5. First aid kit.
- B) Precautions to be taken for the journey:
1. Ensure engine oil and transmission oil are up to the level.
  2. Adequate fuel in the fuel tank.
- C) Check your scooter for the following:
1. Tightness of all bolts and nuts with correct torque value.
  2. Fitness of tyres / tyre pressure / tread depth.
  3. All bulbs, indicator lamps and horn functioning.
  4. Smooth functioning of all cables and their free play.
  5. Smoothness of steering operation.
  6. Front / rear brake function and rear brake lamp working.

7. Front fork for any abnormality.
8. Spark plug gap and condition of spark plug.
9. Air filter element cleanliness.
10. Lubrication of all items mentioned in the periodic maintenance schedule.
11. Any other job as necessary.
12. Have your vehicle checked at any TVS Motor Company Authorised Main Dealer or Authorised Dealer.



### Caution

*Long journey are to be taken only after the running-in period of 1000 km.*

**TVS Motor Company Limited ('the Company') give this warranty with respect to the TVS Scooty Zest manufactured by the Company.**

While the Company has taken every care to maintain quality in the manufacture of the TVS Scooty Zest, the above said warranty is subject to other terms of warranty:

During 5 years from the date of purchase or during the first 50,000 km of run for the vehicle in the hands of original retail purchaser, whichever is earlier, the parts of the vehicle covered under warranty which prove to the satisfaction of the Company to have a manufacturing defect will be repaired or replaced free of cost.

The Company's obligation under this warranty is limited to repairing or replacing, free of cost, those parts of the vehicle which upon examination by the Company may prove to the Company's satisfaction to have a manufacturing defect, and in such cases the Company's decision either to repair or replace the affected parts will be final. In the event of replacement of parts, the Company also reserves the right to use parts of the same brand as the affected parts or any other brand which is used by the Company in the course of manufacture. All parts replaced under this warranty will become the property of the Company and must be returned to the company.

### **Limitations of Warranty:**

This warranty shall not apply to following condition:

1. Any natural wear and tear, including without limitation, aging.
2. Warranty claims on proprietary items such as tyres, tubes and batteries etc., should be preferred by the user directly on the respective manufacturer, as per their warranty terms and the Company shall not be liable in any manner in respect to the same.
  - Battery warranty for "MF type (Maintenance Free)" is applicable for a period of 21 months from the date of charging or 18 months from the date of sale or 20,000 kms, whichever is earlier.
  - Battery warranty for "Lead Acid type" is applicable for a period of 15 months from date of charging or 12 months from date of sale or 10000 kms whichever is earlier.
3. Parts repaired or replaced under this warranty are warranted only throughout the remainder of the original warranty period.

4. The Company is not liable for any delay in servicing due to reasons beyond the control of the Company or any of its Authorised Main Dealers / Authorised Dealers.
5. In any event, the Company is not liable for indirect, remote, incidental or consequential damages.
6. The Company may make any modification or improvement to vehicles in future production at any time without prior notice and without any obligation to install the same on vehicles previously dispatched for sale.
7. Any claim under this warranty will lie only when the customer:
  - takes his vehicle to an Authorised Main Dealer / Authorised Dealer of the Company and reports the problem he / she felt in the vehicle to enable the Authorised Main Dealer / Authorised Dealer to inspect the same and assess the cause for the reported problems.
  - produces to such Authorised Main Dealer / Authorised Dealer the Service Handbook for the concerned vehicle for verification of relevant details.
8. This is the only warranty given by the Company for the TVS Scooty Zest. No employee, Dealer or other person is authorised to extend or enlarge this warranty.

 **Warning**

*Modifications to this vehicle not approved by the TVS Motor Company may cause loss of performance and render it unsafe for use and disqualifies for warranty coverage also.*

**Following Toll Free numbers can be contacted for battery related queries if any.**

Incase of EXIDE battery, call :- 1800 103 5454

Incase of AMCO battery, call :- 1800 425 0096

Incase of TATA GREEN battery, call :- 1800 419 8888

Incase of AMARON battery, call :- 1800 425 5858

**Following Toll Free numbers can be contacted for Tyre related queries if any.**

Incase of TVS Srichakra, call :- 04522443300

Incase of JK tyre, call :- 18002581100

Incase of Maxxis tyre, call :- 1800 532 2888

## List of parts not covered under warranty

ITEM	WHAT TO CHECK FOR
Normal Maintenance Operations	Engine tune-up, decarbonizing, fuel system cleaning, oil changes, head light focusing, fastener retightening, ignition timing, clutch and brakes as well as other normal adjustments.
Wear and Tear Items	Chain, sprockets, clutch and brake linings, fasteners, shims, washers, oil seals, gaskets, O' rings and spokes etc.
Electrical	Bulbs, fuse, DRL, AHO.
Service Maintenance Parts	Oil filters, spark plug, air filter, SAI filter, oils and brake fluid
Rubber, Rexine and Plastic Items	All hoses, pipes and plastic aesthetics
Proprietary Items	<p>Battery, tyres and tubes (the warranty terms are subject to our agreement with proprietary OEM)</p> <p>(Battery warranty for "MF type (Maintenance Free)" is applicable for a period of 21 months from the date of charging or 18 months from the date of sale or 20,000 kms, whichever is earlier).</p> <p>(Battery warranty for "Lead Acid type" is applicable for a period of 15 months from date of charging or 12 months from date of sale or 10000 kms whichever is earlier).</p>
Others Factors	Parts of the vehicle getting affected due to atmospheric effect / environmental factors (rusting, paint peel off etc.). However, depending on the vehicle usage condition, warranty would be accepted up to 2 years from the date of purchase.
	Parts of the vehicle which have been tampered with, altered, repaired or replaced by persons not authorised by the Company and which in the sole judgement of the Company affect the performance of the vehicle.

## List of parts not covered under warranty

ITEM	WHAT TO CHECK FOR
Others Factors	Parts suffering damage or resultant damage by accident, misuse, negligent treatment, use of bad quality lubricants or impure fuel or by omission to follow the guidance and instructions contained in this owner's manual.
	Vehicles on which engine number or chassis number is deleted, defaced or altered.
	Vehicles on which any warranty service including scheduled paid service is not availed when it falls due (at TVS Motor Company Authorised Main Dealer / Authorised Dealer).
	<p>Vehicles sold or transferred by original retail purchaser.</p> <p>Vehicles used for racing or any competition or used otherwise than for ordinary personal transportation.</p> <p>Vehicles attached with side cars etc.</p> <p>Vehicles which have been taken out of India.</p> <p>Vehicles affected by natural calamities like flood, earthquake, tsunami, storm etc.,</p>
	If the vehicle has been used for commercial purpose like taxi or used for rental or hiring or any other purpose other than regular personal transportation.

## SERVICE INFORMATION

There are seventeen services for TVS Scooty Zest during warranty period. Of these, first four services are free services for which labour charges are free. In addition to these four free services, we have a scheme of thirteen pay services. For keeping the maintenance track of your vehicle, free and pay service record sheets are attached in the Service Handbook given to you during the time of your vehicle purchase. Please have the relevant record sheet filled by the Dealer who is carrying out the maintenance service.

For availing any of the warranty services, please take your vehicle and your Service Handbook to any of our Authorised Main Dealers or any of our Authorised Dealer. After effecting the service the Authorised Main Dealer or the Authorised Dealer will affix their stamp on the last column of free or pay service record sheet of Service Handbook for your record and reference. An OTP would be sent to customer's registered mobile number. The same to be shared with the servicing Dealer on or before vehicle delivery.

Periodic maintenance always helps good performance of an automobile and our services are planned to keep your TVS Scooty Zest performing good. **Please note that carrying out the services for your vehicle at scheduled intervals at any of the TVS Motor Company Authorised Main Dealer / Authorised Dealer is necessary for availing of warranty.** And please also remember that, after the services are over, periodic servicing of your vehicle at appropriate intervals, depending upon its extent of use, will keep your vehicle at its best level of performance.

In case you need any clarification or assistance, please feel free to write to us mentioning the frame number, engine number and date of purchase of your vehicle also the name and place of the Authorised Main Dealer / Authorised Dealer from whom you bought the vehicle and getting it serviced.

### Service Department

**TVS MOTOR COMPANY LIMITED**

**P.O. Box No. 4, Harita, Hosur - 635 109,**

**TAMILNADU, INDIA.**

**Toll free no:- 1800-258-7111**

**Planned Service Schedule (kms or month whichever of the two occurs early)\***

SI.No.	Service	Type	Kms	Months
1	1st Service	Free	500 ~ 750	2
2	2nd Service		2500 ~ 3000	4
3	3rd Service		5000 ~ 6000	8
4	4th Service		8500 ~ 9000	12
5	5th Service	Pay	11500 ~ 12000	16
6	6th Service		14500 ~ 15000	20
7	7th Service		17500 ~ 18000	24
8	8th Service		20500 ~ 21000	28
9	9th Service		23500 ~ 24000	32
10	10th Service		26500 ~ 27000	36
11	11th Service		29500 ~ 30000	40



Sl.No.	Service	Type	Kms	Months
12	12th Service	Pay	32500 ~ 33000	44
13	13th Service		35500 ~ 36000	48
14	14th Service		38500 ~ 39000	51
15	15th Service		41500 ~ 42000	54
16	16th Service		44500 ~ 45000	57
17	17th Service		47500 ~ 48000	60

**i Note**

*Free service enables the customer to avail the service at free of labour charges. Charges for the pay service should be borne by the customer. Cost of engine oil, periodic maintenance parts, filter, brake fluids, all types of greases, petroleum jelly, distilled water, chain cleaner, lubricants, coolants, cleaning cloths for both free and paid services are chargeable to the customer.*

*\* Please remember that, after the above schedule, periodic servicing of your vehicle at appropriate intervals, depending upon its extent of use, will keep your vehicle at its best level of performance.*

**MANUFACTURER** : TVS MOTOR COMPANY LIMITED  
P.B. No1, Bythahalli, Kadakola post, Mysore - 571 311, India.

### ENGINE

Type : Single cylinder, 4 stroke, fuel injection, air cooled, spark ignition engine

Cylinder bore : 53.5 mm

Stroke : 48.8 mm

Piston displacement : 109.7 cc

Compression ratio : 10 ± 0.5 : 1

Air filter : Viscous paper filter element

Oil filter : Wire mesh

Lubrication system : Forced wet sump

Maximum power in kW : 5.75 @ 7500 rpm

Maximum torque in Nm : 8.8 @ 5500 rpm

Maximum speed : 80 km/h

Engine idling rpm<sup>†</sup> : 1450 ± 100 rpm

Starting system : Electric starter / kick starter

Emission norms : BSVI

### TRANSMISSION

Clutch : Dry - Centrifugal clutch

Primary transmission : CVT (Continuous Variable Transmission)

Primary reduction : 2.65 to 0.82

Secondary reduction : 9.09

### CHASSIS

Overall length : 1770 mm

Overall width : 660 mm

Overall height : 1139 mm

Ground clearance : 135 mm (unladen)

Wheel base : 1250 mm

Kerb weight (with toolkit and 90% of fuel) : 103 kg

Pay load : 130 kg

Maximum laden weight : 233 kg

Frame : Duplex tubular frame

Front suspension : Telescopic hydraulic type

Rear suspension : Toggle link, coil spring with hydraulic damper

Trail length : 95.4 mm

<sup>†</sup> Under warm condition

**TYRE****Tyre size**

Front	: 90/100-10 53J (Tubeless)
Rear	: 90/90-10 50J (Tubeless)

**Tyre pressure**

Front	: 1.69 kg/cm <sup>2</sup> (24 PSI)
Rear - solo	: 1.97 kg/cm <sup>2</sup> (28 PSI)
Rear - dual	: 2.25 kg/cm <sup>2</sup> (32 PSI)

**BRAKES**

Front	: 110 mm dia drum (hand operated)
Rear	: 130 mm dia drum (hand operated)

**ELECTRICAL**

Ignition system	: ECU controlled ignition
Spark plug	: BOSCH UR5KCW / CHAMPION RG8MC4
Spark plug gap	: 0.9 to 1.0 mm / 1.0 to 1.1 mm
Battery type	: 12V, 5Ah Lead Acid
Generator	: Fly wheel magneto 12V, 130W
Head lamp	: 12V, 35/35W
DRL	: 12V, LED
Tail / brake lamp	: 12V, LED

Turn signal lamp	: 12V, 10W x 4
Number plate lamp	: 12V, 5W
Speedometer lamp bulb	: 12V, 1.7W x 2
Turn signal indicator lamp bulb	: 12V, 1.7W x 2
High beam indicator lamp bulb	: 12V, 1.7W x 1
Economy mode indicator lamp	: 12V, LED
Malfunction indicator lamp	: 12V, LED
Side stand indicator lamp	: 12V, LED
Horn	: 12V, DC
Fuse (blade type)	: 12V, 15A x 1 : 12V, 10A x 1

**Caution**

*Using the bulb other than the specified rating can result in overloading of the electrical system or premature failure of the bulb.*

**CAPACITIES**

Fuel tank capacity#	: 4.9 l
Fuel	: BS VI petrol with minimum RON 91 (containing upto 10% of ethanol by volume)
Engine oil grade	: TVSTRU4 SKUUTA oil (SAE 10W30 API-SL, JASO MB)
Engine oil capacity	: 750 ~ 800 ml (during regular service) 800 ml (during disassembly)
Transmission oil capacity	: 100 ml (during regular service) 120ml (incase of disassembly)
Front fork oil grade	: IOC, Gabriel Premium front fork oil
Front fork oil capacity	: 53 ± 1 cc per leg

***i* Note**

*Specifications are subject to change without notice.*

# *The fuel tank is not a measuring instrument and the capacity of fuel tank may slightly vary from the indicated capacity.*



**Drive In.**

**Drive Out.**



**Say bye-bye to waiting time  
for servicing your bike.**

**Get your vehicle serviced in 1 hour at no additional cost. Contact your nearest Dealership for details.<sup>†</sup>**

<sup>†</sup>Facility available at selected Dealerships only. Terms and conditions apply





# Busy Life? Easy Servicing!

**Now, service your bike anywhere, anytime.**

- ★ Service the vehicle at your door step.
- ★ Available for regular maintenance or breakdown service only.
- ★ Offered at nominal convenience charges.

**Contact your nearest Dealership for details.<sup>†</sup>**

<sup>†</sup>Facility available at selected Dealerships only. Terms and conditions apply

**TVS**   
**geared  
to care**  
**Pickup &  
Drop**

# Busy Life? Easy Servicing!

**Now, service your bike anywhere, anytime.**

- ★ Service the vehicle at your door step.
- ★ Available for regular maintenance or breakdown service only.
- ★ Offered at nominal convenience charges.

**Contact your nearest Dealership for details.<sup>†</sup>**

<sup>†</sup>Facility available at selected Dealerships only. Terms and conditions apply



## GENERAL INFORMATION



Dear Customer,

It is mandatory under the Motor Vehicles Act to insure all motor vehicles. No motor vehicle can be used in a public place without a valid policy of insurance issued by an authorised insurer. Driving a motor vehicle without any such insurance is an offense under Motor Vehicles Act.

To assist our Customers on their insurance requirements such as the prompt issue and renewal of policies as well as expeditious settlement of claims if any, our preferred insurers are:









TVS Motor Company Limited, P.B. No.4, Harita, Hosur - 635 109, Tamil Nadu, India. Telephone: +91 (4344)276780 Fax: +91(4344)277311/276878  
[www.facebook.com/scootygirls](http://www.facebook.com/scootygirls) | [www.tvsscooty.com](http://www.tvsscooty.com) | [www.tvsmotor.in](http://www.tvsmotor.in)